

Energy Control Unit

The intelligent choice to save money

ASSA ABLOY Global Solutions offers a complete range of in-room Energy Control Units, the perfect combination to provide in-room comfort to your guests and saving energy and money when the guests are not in their room.

Compatible with the same VingCard room keycard, and intelligent to differentiate guest keycards and staff keycards. Thus, limiting the use of air conditioning and other electrical equipment in the room only to your guests and not to your hotel staff.



FEATURES

- : Disconnects electrical equipment and air conditioning when guests are outside the room, thus saving money.
- : Courtesy timer for guests when removing the keycard from the Energy Control Unit.
- : Simple installation.
- : It only works with hotel specific keycards⁽¹⁾.

¹. Only for Intelligent Magnetic Stripe and Intelligent RFID.

TECHNICAL DATA

	STANDARD	INTELLIGENT MAGNETIC STRIPE	INTELLIGENT RFID
Descriptions:	Mechanical temporized energy saver.	Only operates with hotel specific magnetic striped keycards.	Only operates with hotel specific RFID keycards.
Guest/Staff keycard		It prevents hotel staff from using certain electrical equipment in the room (air conditioning, TV, phone etc.) while cleaning the rooms.	It prevents hotel staff from using certain electrical equipment in the room (air conditioning, TV, phone etc.) while cleaning the rooms.
Voltage:	110/220 Vac. Tolerance 10%.	110/220 Vac. Tolerance 10%.	110/220 Vac. Tolerance 10%.
Consumption:		Nominal of 10 m/Amp. Max. of 20 m/Amp.	Nominal of 10 m/Amp. Max. of 20 m/Amp.
Frequency:	50-60 Hz	50-60 Hz	50 - 60 Hz
Output relay:	1 relay. Power of cutting: 10 A, 250 V-, cos = 1 6 A, 250 V-, cos = 0,6 Incandescent max. load 8 A - Halogen max. load 8 A	2 relays. One according to the power supply and other potential free. Power of cutting: 10 A, 250 V-, cos = 1 6 A, 250 V-, cos = 0,6 Incandescent max. load 8 A - Halogen max. load 8 A	2 relays. One according to the power supply and other potential free. Power of cutting: 10 A, 250 V-, cos = 1 6 A, 250 V-, cos = 0,6 Incandescent max. load 8 A - Halogen max. load 8 A
Size mm: inch:	Height 132 • Width 97 • Depth 35 Height 5,20 • Width 3,82 • Depth 1,38	Height 132 • Width 97 • Depth 35 Height 5,20 • Width 3,82 • Depth 1,38	Height 132 • Width 97 • Depth 35 Height 5,20 • Width 3,82 • Depth 1,38
Weight grams pounds	186 grams 0,41	210 grams 0,46	210 grams 0,46
Box:	FIREPROOF material (BG3(H)) according to norm UL 94 V-0.	FIREPROOF material (BG3(H)) according to norm UL 94 V-0.	FIREPROOF material (BG3(H)) according to norm UL 94 V-0.

Standard Connecting Diagram:

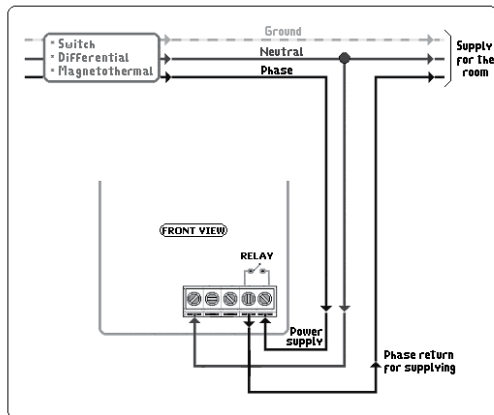

Intelligent Magnetic Stripe and RFID Connecting Diagram:

